



## 5.5 t TELEHANDLER

# 355E

 123 kW /  5.5 t /  8.5 m /  **MULTICAB**

Stage **V**



# The telehandler. With SML power.

Our Multi Line telehandler, developed for industrial use, combines the advantages of both telehandler and wheel loader technology in one unique machine. We call these advantages SML power. A specialist team develops and produces this unique product range at our Wackersdorf plant. Built for users who expect more than just a traditional telehandler.

## THE BEST OF BOTH WORLDS



Telehandler or wheel loader?  
Choose both!

→ [www.sennebogen.com/news/videos/sennebogen-sml-power-the-best-of-both-worlds](http://www.sennebogen.com/news/videos/sennebogen-sml-power-the-best-of-both-worlds)

**Optimum power transmission**  
thanks to Z kinematics

**Hydraulically elevating cab**  
for unique visibility

**Multi-functional**  
hydraulics for a wide range of attachments

**Robust steel construction**  
for demanding applications

**Powerful drive train**  
for high traction and driving speeds,  
Stage V engine for high power and torque



EVERYONE TALKS ABOUT VISIBILITY. WE ACTUALLY DELIVER IT.

ELEVATING CAB AND 360° ALL-ROUND VISIBILITY



Take a look inside the elevating cab and enjoy the view.

[www.sennebogen.com/news/videos/sennebogen-sml-power-unique-overview-for-the-operator](http://www.sennebogen.com/news/videos/sennebogen-sml-power-unique-overview-for-the-operator)

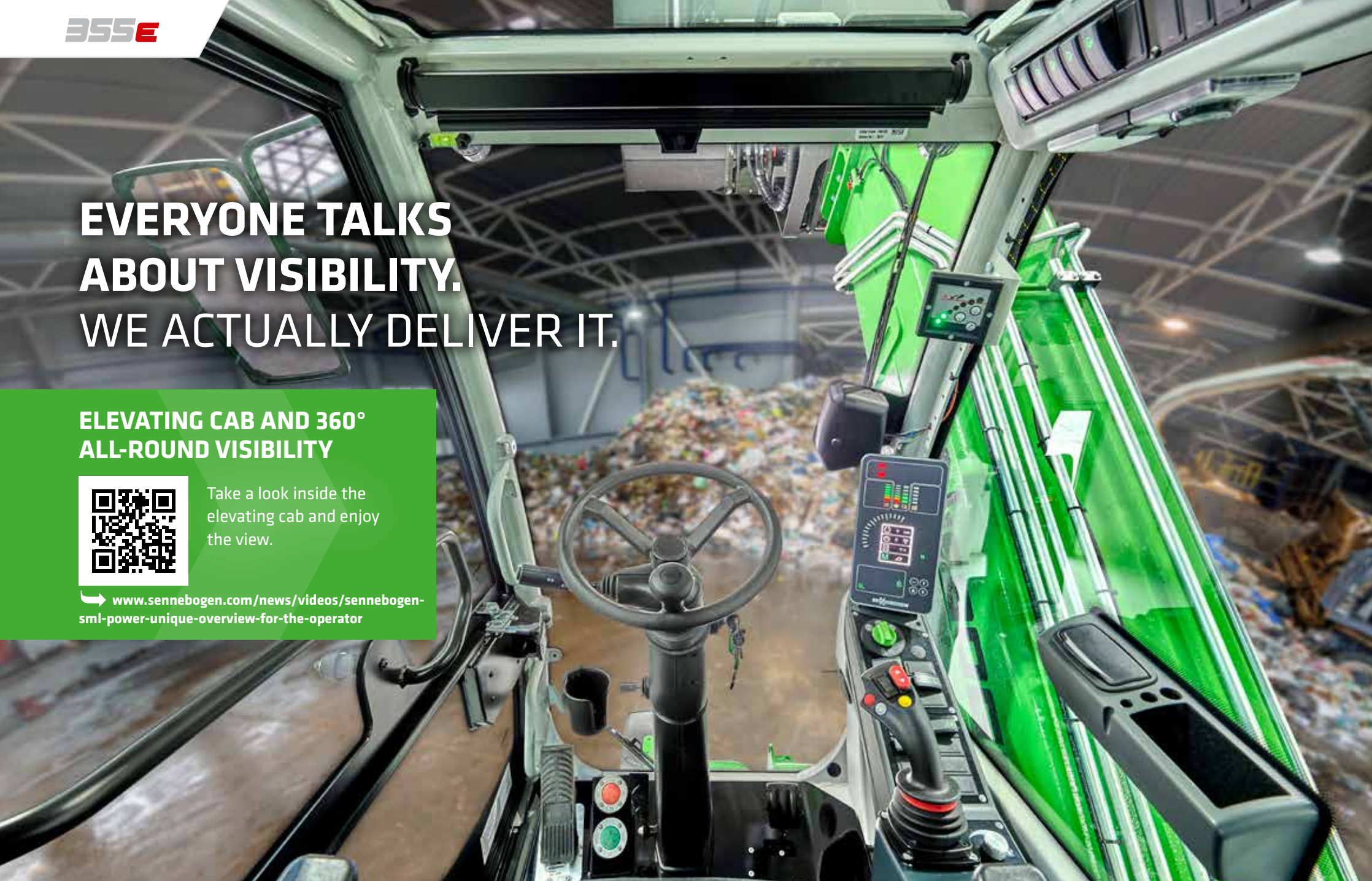

OPTIMAL VISIBILITY CONDITIONS

- **Optimal loading process thanks to an ideal view**  
into the truck or container provided by the elevating cab's 4.25 m viewing height
- **Safety even when maneuvering**  
Good view of all four of the machine's tires
- **Greater visibility and safety**  
True 360° all-round visibility thanks to large glass panels

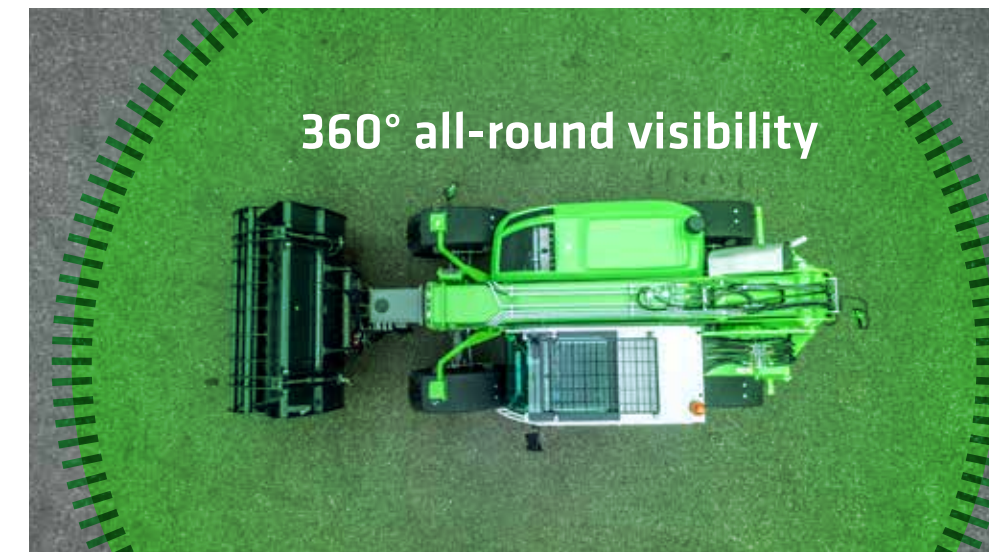
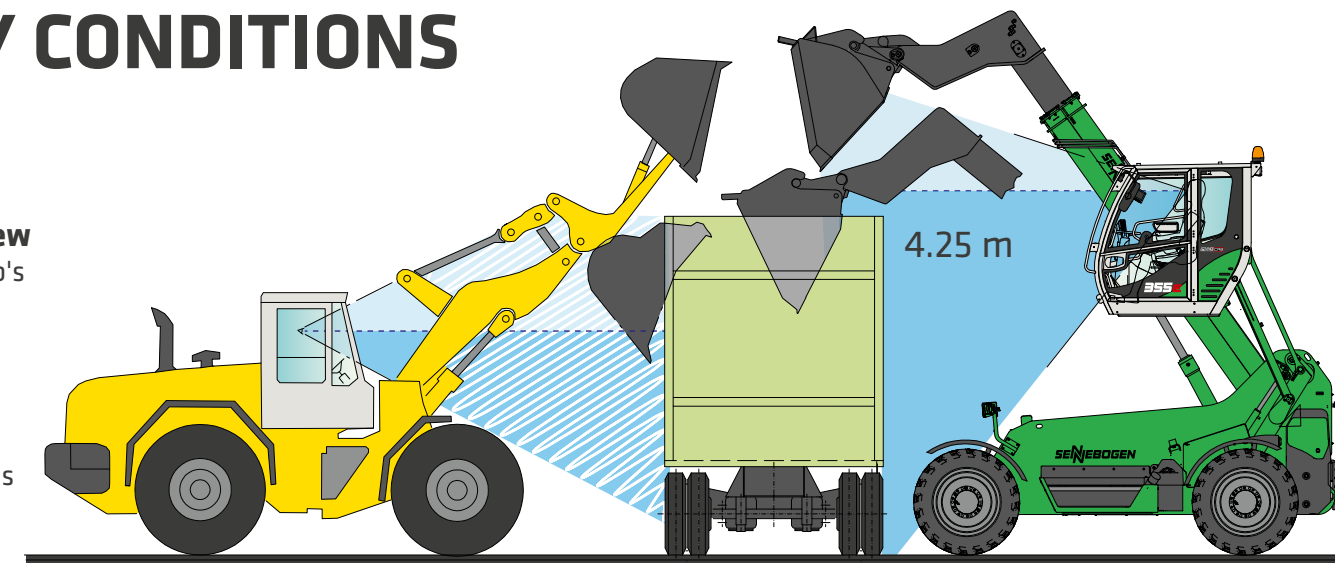





GREATER RANGE.  
MORE BREAK-AWAY FORCE.

## ROBUST. DOWN TO THE LAST DETAIL.

### STEEL FRAME

The machine's high-strength solid steel frame meets the most demanding service life requirements and has been optimized using the FEM (finite element method). It relishes demanding and dynamic applications. SENNEBOGEN's own steel construction experience ensures the best possible quality.

### STEEL TELESCOPIC BOOM

The robust telescopic boom has been designed with state-of-the-art tools and optimized for heavy-duty applications. The central positioning and sophisticated shape of the boom optimally transfer the forces into the body. Stress-free operation enables end position damping on both sides in the telescopic cylinder.

The central and side-guided design optimally absorbs all thrust forces and the robust body remains dimensionally stable. The telescopic boom is located in the best possible position - with the elevating cab, the operator can always see along the boom.

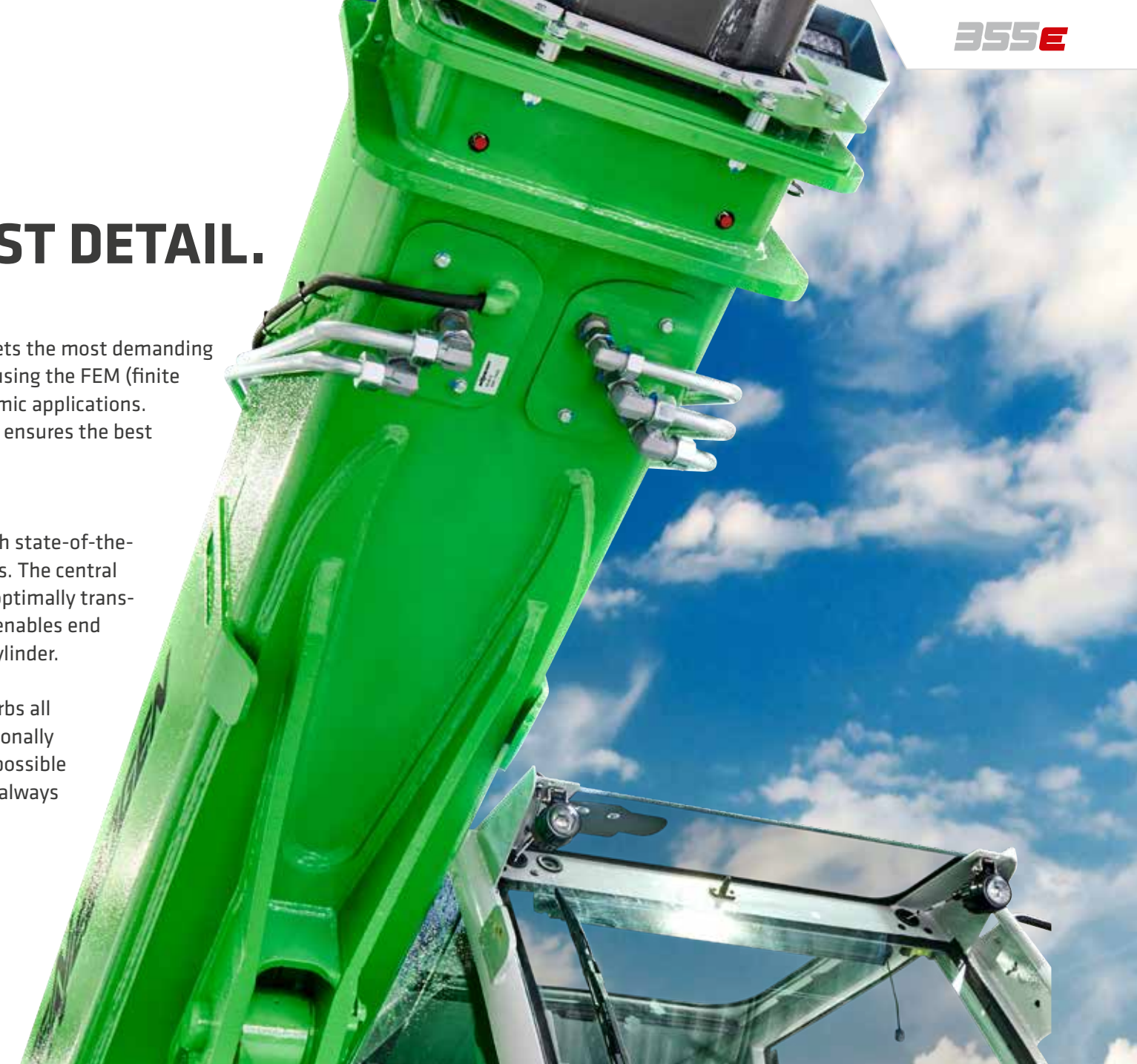



## THE TELEHANDLER WITH WHEEL LOADER TECHNOLOGY.

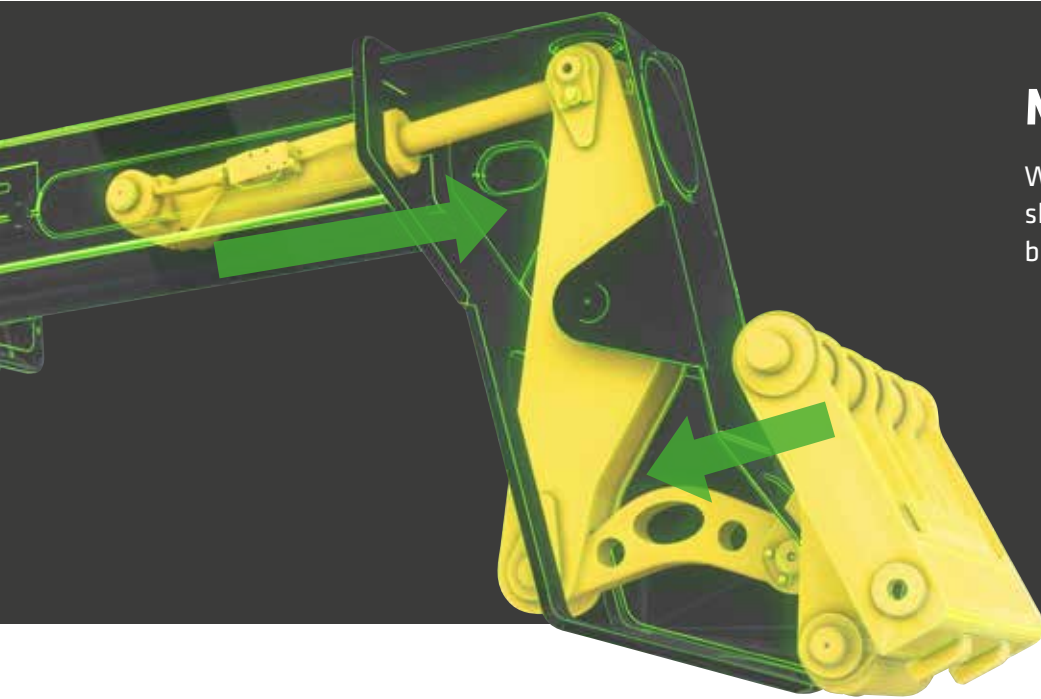

### Maximum break-away force

With the SENNEBOGEN 355 E, you get a real powerhouse with shovel operation. The Z kinematics steer the forces into the bucket in the best way - well known from wheel loaders.

#### Z KINEMATICS IN DETAIL

Watch the video to see how the Z kinematics work and the benefits they offer.



→ [www.sennebogen.com/news/videos/sennebogen-sml-power-more-breakaway-force-and-reach](http://www.sennebogen.com/news/videos/sennebogen-sml-power-more-breakaway-force-and-reach)

### Tool change at the push of a button

The robust SENNEBOGEN hydraulic quick-change system perfectly complements the telehandler's Z kinematics: reinforced frame, large-scale bolts, dual-action locking cylinder – everything can be operated at the push of a button.



**STRONG.**  
LIKE NO OTHER.





## CONSTANTLY AN OPTIMAL MIX OF TENSILE FORCE AND SPEED.



## ALWAYS FULL POWER.

### THE POWERFUL AND CLEVER DRIVE TRAIN

The 355 E's variable travel drive always supplies generous amounts of power thanks to the combined efforts of the diesel engine and the hydraulic pumps.

The innovative control of the drive unit ensures that the drive engine in the Compact Drive transmission provides fast travelling or a high torque when required.

The system will automatically give you the optimal setting for fast travel, handling an uphill gradient, or picking up heavy materials.

By default, the machine travels at a maximum speed of 20 km/h. But speeds of just under 40 km/h are no problem for the powerful unit.



Max. tensile/thrust force (90 kN/85 kN) or max. vehicle speed (40 km/h)



### COMPACT DRIVE®

The series standard Compact Drive transmission operates extremely effectively and with low fuel consumption in a closed circuit. The technically advanced components of the transmission – adjustable hydraulic and gear drive – work optimally together and ensure a highly flexible working range.

Similarly, this unit impresses with its compact and space-saving design, which is also very durable and extremely reliable – whether at high speeds or high thrust/traction forces.





ROPS/TOPS tested

**MULTI**CAB

**THE PREMIUM CAB.**

With our comfort cab operators can concentrate on their work and relax at the same time. Protected against excessive noise and vibration, operators can concentrate themselves on their work. The excellent view from the cab, and the ergonomically arranged and free to move control elements ensure a pleasant work situation. The multiple storage options, various connections (USB, 12 V, 24 V), and an air conditioning system as standard complete the concept of "working in the comfort zone".



Free to move console and control elements



Air conditioning as standard for pleasant working conditions



Comfortable foot pedals for continuous cab height adjustment



**WORK IN PERFECT COMFORT.  
BOOM DAMPING AND  
CAB VIBRATION DAMPER.**



# SOPHISTICATED TECHNOLOGY. ALWAYS RELIABLE.



## REVERSIBLE FAN AS STANDARD



Video: The reversible fan provides many benefits, especially in dusty environments and when in continuous use.

[www.sennebogen.com/news/videos/sennebogen-sml-power-built-for-multi-shift-operations](http://www.sennebogen.com/news/videos/sennebogen-sml-power-built-for-multi-shift-operations)

## SOPHISTICATED DOWN TO THE LAST DETAIL

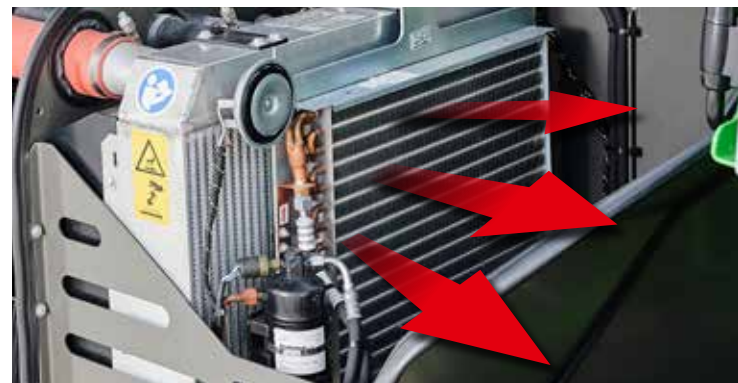

The SENNEBOGEN 355 E always works productively. The powerful reversible fan comes as standard and reliably ensures free air intake and thus optimal cooling performance, even in the most adverse conditions.



Working with fewer refueling stops: Thanks to an enormous diesel tank, the 355 E keeps you moving for longer, even in multi-shift operations.

# CONTROLLED USE OF FORCE ON SLOPES

Powerful and low-emission stage V engine with 123 kW power





# TECHNICAL DATA, EQUIPMENT

## OPERATING DATA

OPERATING WEIGHT <sup>1</sup>	11.800 kg
STACKING HEIGHT	8.500 mm
MAX. LOAD CAPACITY (LSP 600 MM)	5.500 kg
MAX. LOAD CAPACITY AT MAX. HEIGHT	4.850 kg
MAX. LOAD CAPACITY AT MAX. REACH	2.400 kg
MAX. TRAVEL SPEED	20 (40) km/h
TENSILE FORCE <sup>2</sup>	76 kN
BREAK-AWAY FORCE ON THE SHOVEL <sup>3</sup>	85 kN

## DIESEL ENGINE

TYPE	Stage V Cummins B4.5-C165 FR95723 Nominal engine power: 123 kW / 2200 rpm Standard operating point: 123 kW / 2200 rpm ECO operating point: 111 kW / 1500 rpm
EXHAUST AFTERTREATMENT	DOC + SCR + DPF
DISPLACEMENT	4.5 l
MAX. TORQUE	763 Nm

## HYDRAULIC SYSTEM

OPERATING PUMP	Load sensing axial piston variable displacement pump
OUTPUT	200 l/min
WORKING PRESSURE	310 bar
OUTPUT ZH <sup>4</sup>	100 l/min

## POWER TRANSMISSION

STEERING ANGLE	36°
DIFFERENTIAL LOCK	100% selectable on the rear axle
SERVICE BRAKE	internal hydraulically operated brake
PARKING BRAKE	hydraulically operated spring-loaded cylinder

## TANK CAPACITIES

DIESEL TANK	160 l
HYDRAULIC OIL TANK	120 l
SCR TANK	16 l

1) in line with ISO 6016 (weight of the machine with all standard equipment, without a load, with a full fuel tank, with other liquid tanks full [water, hydraulic oil, brake fluid] and the weight of the operator [75 kg ± 3 kg])  
 2) depending on machine version  
 3) calculated  
 4) ZH = auxiliary hydraulics

Subject to technical changes. Additional options available upon request.

# LOAD RATINGS AND OPERATIONAL RANGE

Without hydraulic level compensation / with oscillating axle lock  
 Operation with lifting fork

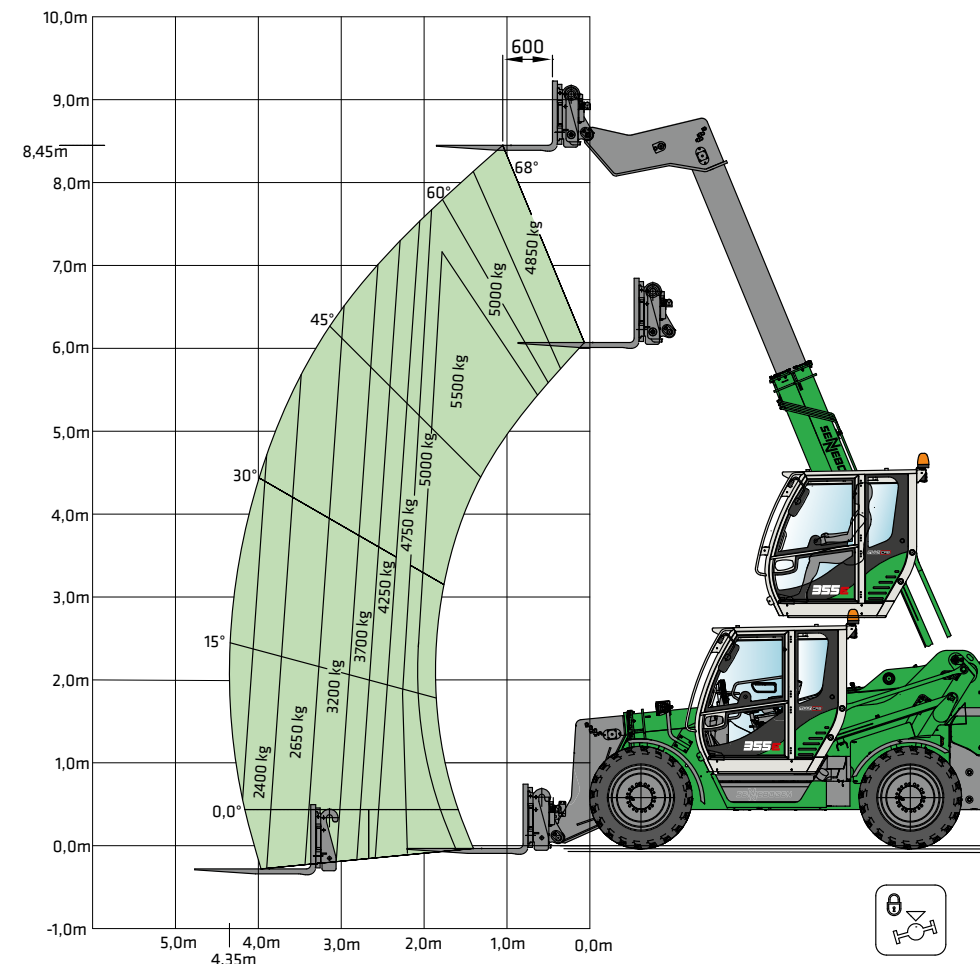

All values as per safety standards DIN EN1459 / DIN ISO 22915-14 and EN 474-3 / ISO 8313. They apply to the SENNEBOGEN standard lifting fork with a maximum deviation of +/- 5° from the horizontal.

Without hydraulic level compensation / with oscillating axle lock  
 Operation with shovel

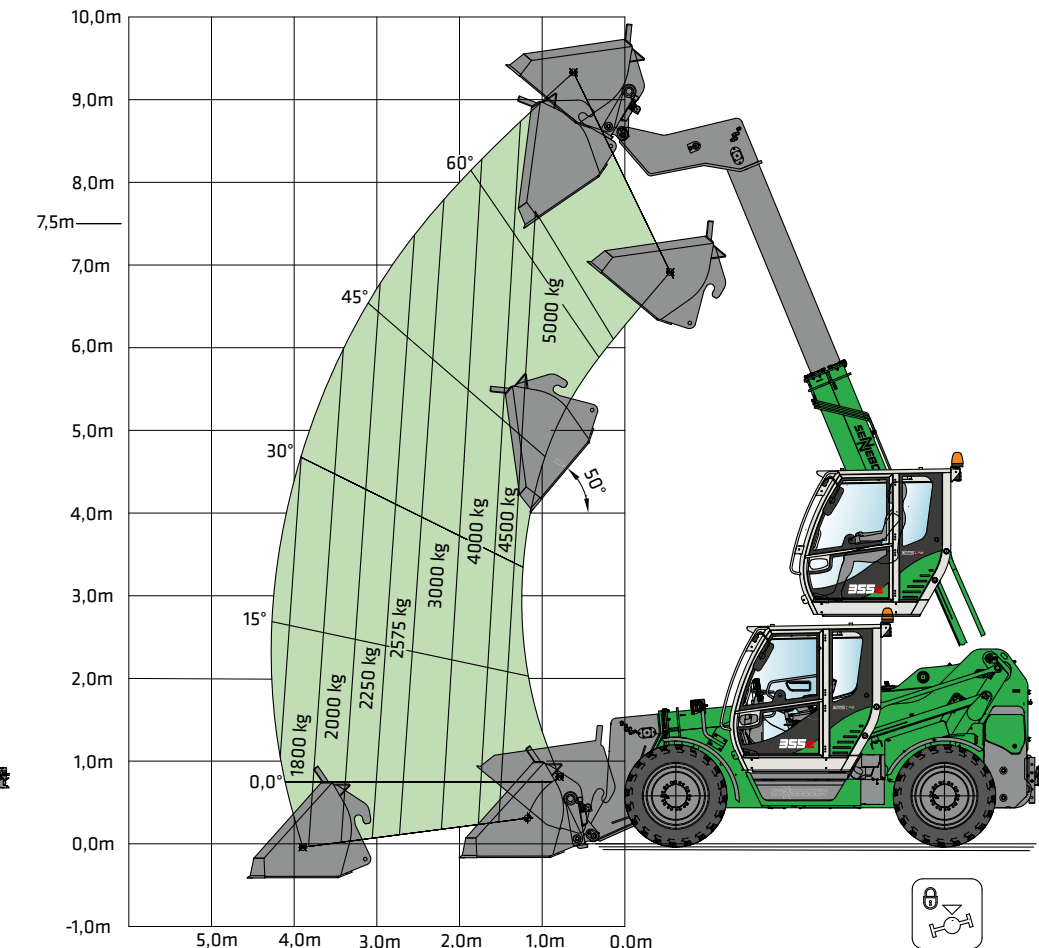

Payload values as per EN 474-3 / ISO 14397-1. They do not exceed 50 % of the tipping load. The dead weight of the shovel is included in the payload. Payloads should be moved in the transport position with the boom retracted and lowered.

CLASSIFICATION: Off-road forklift with variable reach - DIN EN 1459. Subject to technical changes. Additional options available upon request.



# LOAD RATINGS AND OPERATIONAL RANGE

With hydraulic level compensation / with oscillating axle lock  
Operation with lifting fork

Without hydraulic level compensation / without oscillating axle lock  
Operation with lifting fork

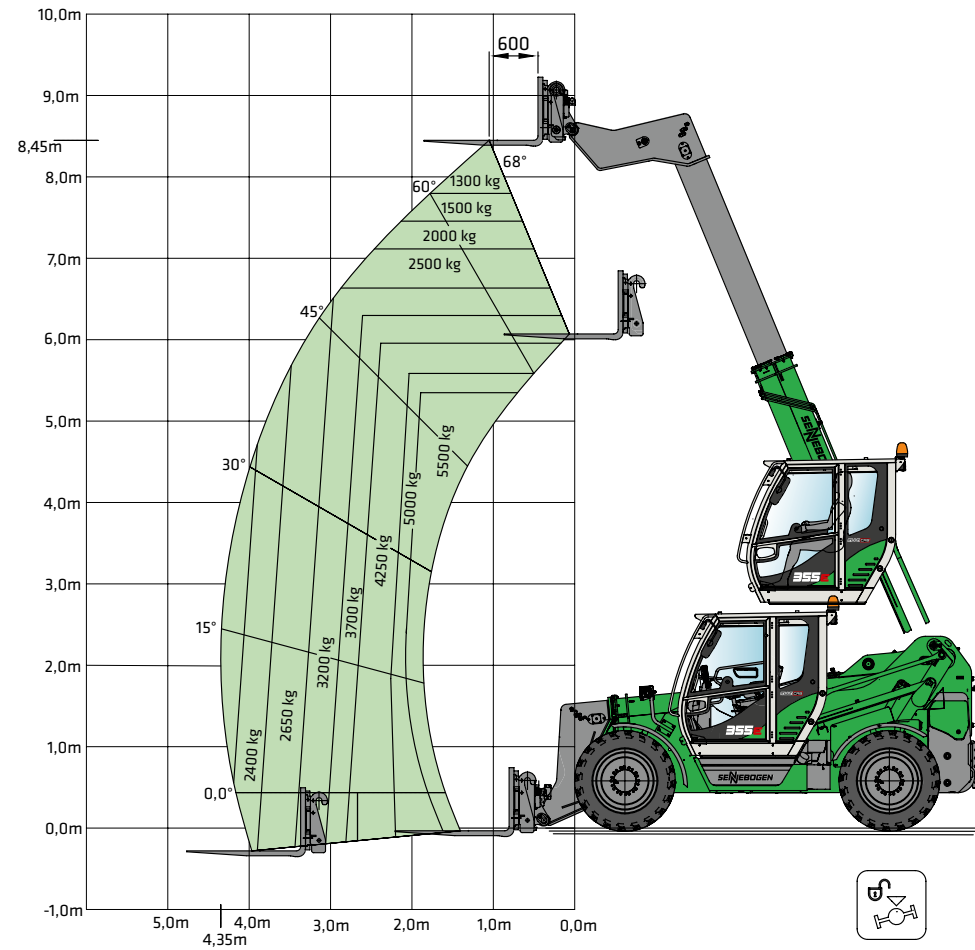
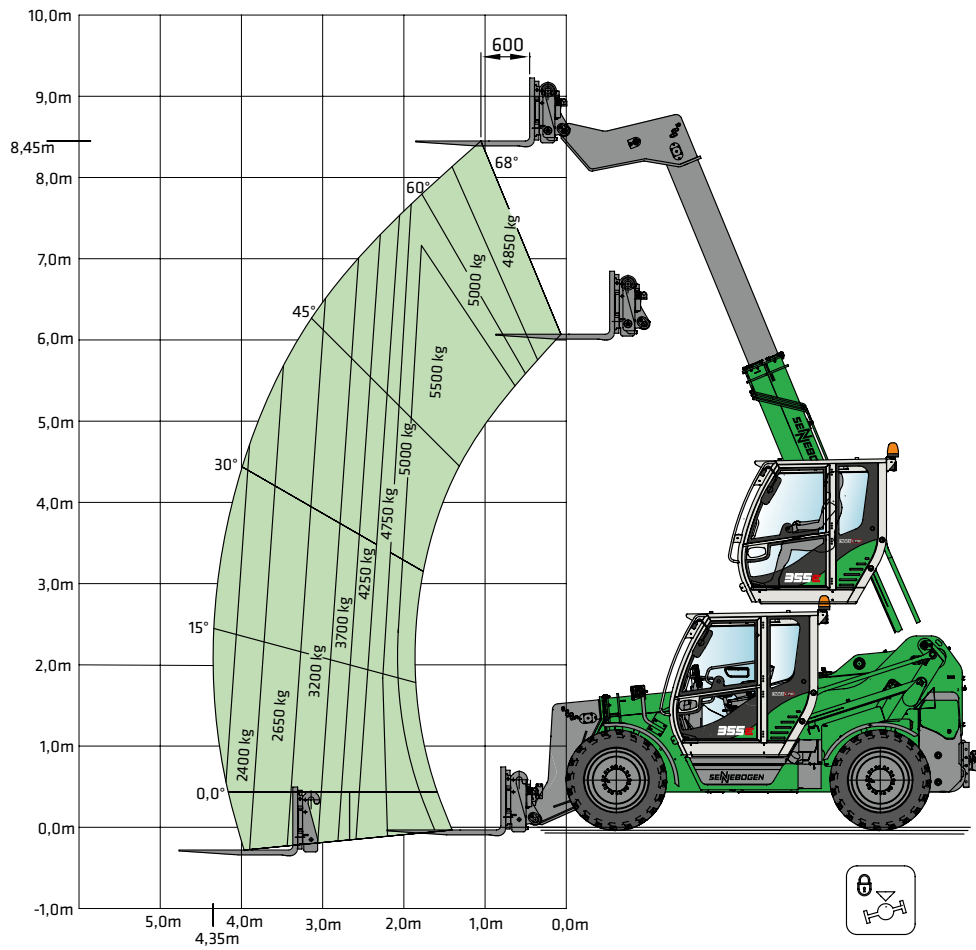

All values as per safety standards DIN EN1459 / DIN ISO 22915-14 and EN 474-3 / ISO 8313. They apply to the Sennebogen standard lifting fork with a maximum deviation of +/- 5° from the horizontal.

All values as per safety standards DIN EN1459 / DIN ISO 22915-14 and EN 474-3 / ISO 8313. They apply to the SENNEBOGEN standard lifting fork with a maximum deviation of +/- 5° from the horizontal.



4.25 m viewing height

FULL POWER.  
FULL VISIBILITY.



## STANDARD EQUIPMENT AND OPTIONAL EXTRAS

### BASIC MODEL

- 355 - Series E SENNEBOGEN Telehandler (Stage V) 123 kW
- Electric engine preheating 230 V
- Pre-separator for air filter, coarse particle degree of separation approx. 98%
- Reversible fan
- Central lubrication system

### TIRES

- 460/70 24 Camso MPT753
- 500/70 R 24 Nokian TRI 2 Steel
- 460/70 R 24 Alliance Multiuse
- 500/70 R 24 Michelin Bibload Hard Surface
- 375/85 24 Camso MPT solid rubber tires
- 15.5 R25 Bridgestone VSDL D2A

### DRIVE AND STEERING

- Continuously variable travel drive 20 km/h
- Continuously variable travel drive 30 km/h
- Continuously variable travel drive 40 km/h
- Crawling function and speed limiter
- Front axle level control
- Tow bar with manual coupling
- Tow bar with automatic coupling; height-adjustable
- Compressed air brake system for towing operation
- Tow bar Pick-Up Hitch

### OPERATOR'S CAB AND EQUIPMENT



- SENNEBOGEN comfort Multicab, vibration-damped with nitrogen accumulator
- Air conditioning with central control unit
- Seat belt / 2 inches
- Air-suspended comfort operator's seat with seat heating
- Cab windshield with bullet proof glass
- Hammer glass safety glazing for left and right cab windows incl. doors
- Bulletproof glass in skylight
- Wipers for skylight
- Wipers for rear windshield
- Protective guard on skylight (level 1) light version
- FOPS protective guard
- Sunblind for skylight, interior
- Sunblind for windshield, interior
- Radio (USB, SD, MP3, Bluetooth)
- Activated carbon filter for cab, 5 filter kits supplied loose

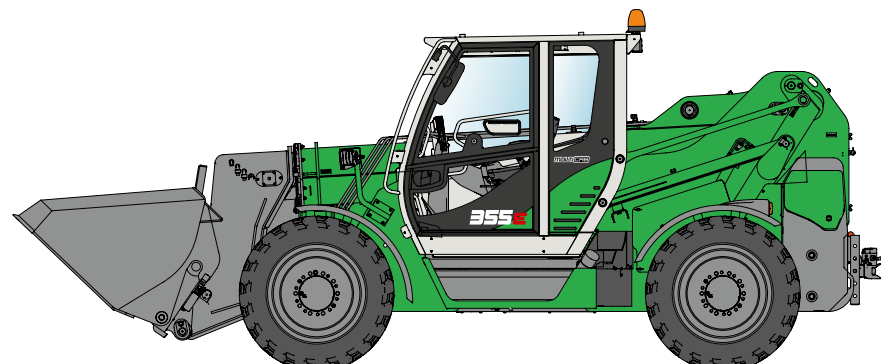

● standard   ○ optional

## OPTIONAL LEVEL CONTROL. FOR ALMOST ANY TILT.





## STANDARD EQUIPMENT AND OPTIONAL EXTRAS

### ADDITIONAL EQUIPMENT

- Mirrors on right and rear
- Camera system - basic package with 1 camera
- Camera system - premium package with 2 cameras

### HYDRAULIC OIL FILLING

- Hydraulic oil Shell Tellus S2 VA 46
- Bio oil filling (PANOLIN HLP Synth 46)
- Hydraulic oil Shell Tellus S4 VX 32 (low temperature oil)

### EQUIPMENT

- Boom damping
- Dirt scraper for telescopic boom

### ADDITIONAL FUNCTIONS FOR ATTACHMENTS

- Continuous operation ZH1\*
- ZH3 Auxiliary hydraulic circuit on boom head\*
- ZH2 auxiliary hydraulic circuit at the rear\*
- Socket for front attachments, 7-pin / 24 V

### LIGHTING AND TRAVEL ALERTS

- Standard lighting package incl. lighting in line with road traffic licensing regulations
- 2 LED headlights on the basic boom: 1 on the left and 1 on the right
- All-round lighting package incl. lighting in line with road traffic licensing regulations
- 1 rotating beacon light on the cab

### SPECIAL ITEMS

- Electric heater for hydraulic tank, 230 V

### QUICK-CHANGE SYSTEM

- SENNEBOGEN hydraulic quickchange system
- VOLVO hydraulic quick change system
- Manitou hydraulic quick change system
- Kramer hydraulic quick change system
- JCB hydraulic quick change system

### PAINT FINISH / COATING

- Standard paint finish: RAL 6018 Green / RAL 7038 Light grey / RAL 7022 Grey
- Special paint finish (1 color) in RAL color
- Special paint finish (multiple colors) in RAL color
- Special paint finish for Multicab only in RAL color

### SENTRACK TELEMETRY SYSTEM

- SENtrack telemetry system including connection fees



● standard    ○ optional    \* ZH = auxiliary hydraulics

## POWERFUL WORK HYDRAULICS

### Powerful drive, economical consumption

Each work function always receives the hydraulic power it requires to operate optimally. Instantaneous signal processing between joystick and engine block ensures sensitive and responsive operation for all the machine's hydraulic functions.

In addition to the main functions – the lift cylinder, tilt cylinder, telescopic cylinder and the elevating cab – the work hydraulics also control the additional hydraulic connections just as effectively.



### EQUIPPED FOR MANY USES



**Auxiliary hydraulics 1 (ZH1)**  
For quick and easy connection of attachments (standard)



**Pressure relief for ZH1**  
Clean and safe attachment change at the push of a button (standard)



**Continuous operation of ZH1**  
With freely definable oil quantity for individual attachments (optional)



**4-pin socket (24 V)**  
for front attachments on the quick release system (optional)

**Additional rear hydraulics ZH2**  
rear hydraulic connection for trailer or similar (optional)

**Additional rear hydraulics ZH3**  
For the operation of demanding attachments with several hydraulic functions (optional)



# SHOVELS

With SENNEBOGEN shovels, you get attachments specially optimized for our telehandler, which match the machine's high quality standards.

Our shovels are designed for the tough working conditions of the recycling industry. The robust design with highly wear-resistant materials and hardened components, and the shape and center of gravity optimization, offer ideal conditions for long-term continuous loads.

Unleash the full potential of our telehandler with SENNEBOGEN shovels:

- /// Utilization of maximum break-away force and payload
- /// Lower fuel consumption
- /// Powertrain stress reduction
- /// Shorter loading cycles
- /// Greater working comfort and safety with the hold-down shovel



### SOIL SHOVEL

1.6 m<sup>3</sup> with and without teeth  
Bulk material density: approx. 1.8 t/m<sup>3</sup>  
Shovel weight: approx. 610 kg



### LOADING SHOVEL

2.5 m<sup>3</sup> for bulk material density of approx. 1.2 t/m<sup>3</sup> (shovel weight: approx. 870 kg)  
3.0 m<sup>3</sup> for bulk material density of approx. 1.1 t/m<sup>3</sup> (shovel weight: approx. 960 kg)  
Shovel weight: approx. 610 kg



### HOLD-DOWN SHOVEL

2.5 m<sup>3</sup> incl. reversible blade bolted to underside for bulk material density of approx. 1.4 t/m<sup>3</sup> (shovel weight: approx. 1,480 kg)  
3.0 m<sup>3</sup> incl. reversible blade bolted to underside for bulk material density of approx. 1.0 t/m<sup>3</sup> (shovel weight: approx. 1,560 kg)



### LIGHT-GOODS SHOVEL

3.5 m<sup>3</sup> for bulk material density of approx. 1.0 t/m<sup>3</sup> (weight: approx. 840 kg)  
4.0 m<sup>3</sup> for bulk material density of approx. 0.9 t/m<sup>3</sup> (weight: approx. 920 kg)

Subject to technical changes. Additional options available upon request.

# TIRES

No matter what application, it's the ground that forms the contact surface with the machine. Therefore, only the right tires can provide optimum safety.

We will provide you with the best tires for your application. Rely on our experience and get advice on achieving the best performance, safety and service life.



Subject to technical changes. Additional options available upon request.



### STANDARD

CAMSO MPT 753 460/70-24  
Universal tire with good traction and balanced handling



### INDUSTRY

NOKIAN TRI 2 STEEL 500/70 R24  
MPT steel reinforced profile for industrial and recycling plants



### OFFROAD

15.5 R25 BRIDGESTONE VSDL D2A  
Extremely robust L5 pneumatic tires for maximum protection, e.g. in scrap yards, quarries or for tough recycling applications



### CONSTRUCTION SITE

MICHELIN BIBLOAD 500/70 R 24  
Radial, for construction sites and aggressive surfaces, comfort tires, smooth running

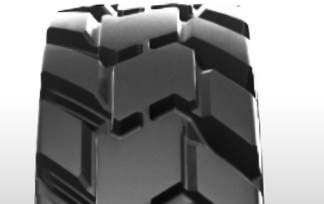

### RECYCLING

CAMSO MPT 793S 375/85-24  
Solid rubber tires 12.00-24. Width approx. 300 mm



# SMALL TURNING RADIUS, BIG IMPACT.

## TURNING RADIUS AND STEERING



This video shows you how surprisingly agile our telehandler is.

<https://www.sennebogen.com/news/videos/sennebogen-sml-power-compact-and-maneuverable>

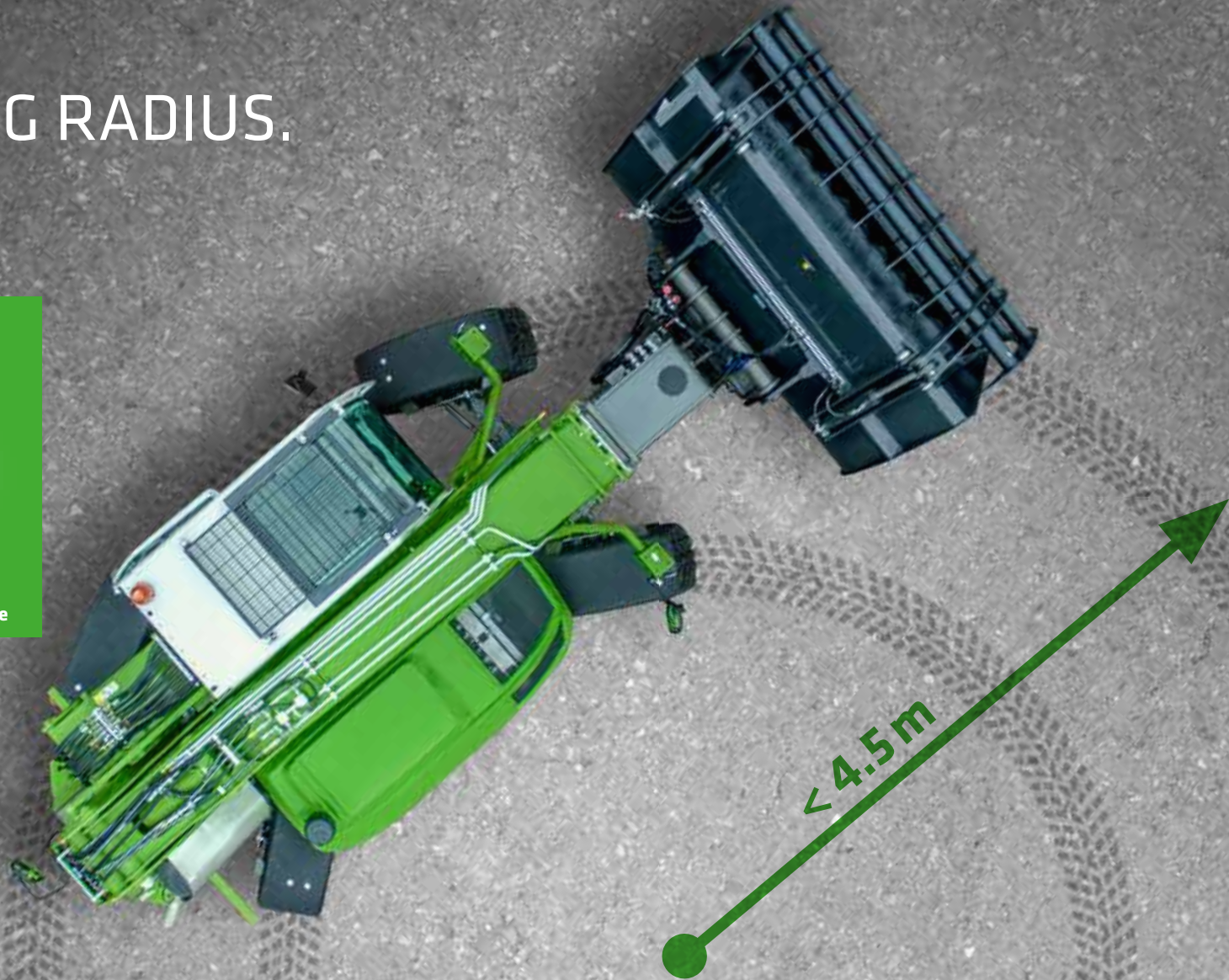

## DIMENSIONS

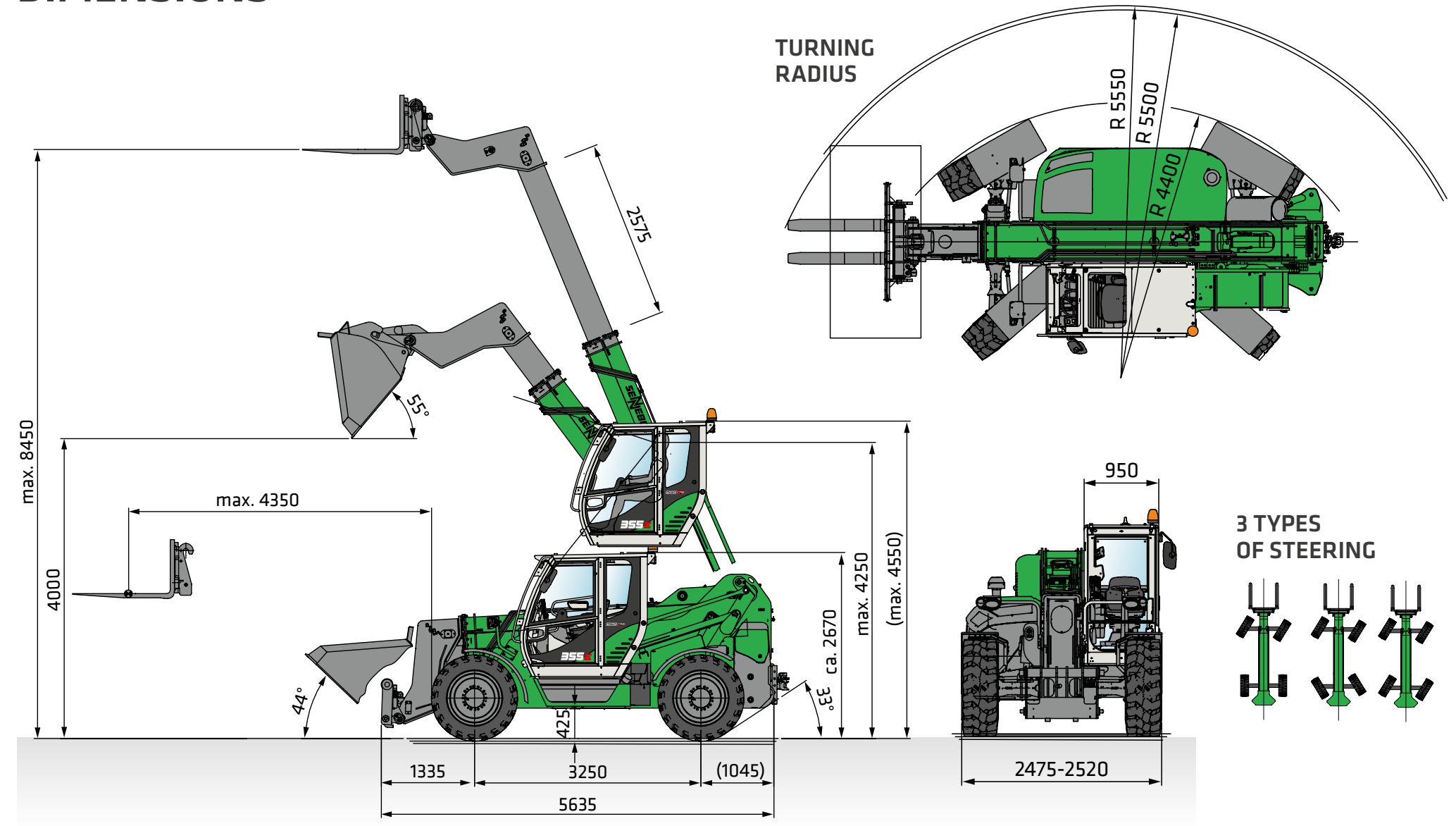

Measurements in [mm] **CLASSIFICATION:** Off-road forklift with variable reach - DIN EN 1459  
Subject to technical changes. Additional options available upon request.



## YOUR MACHINE. MULTI-FUNCTIONAL.

The SENNEBOGEN 355 E is truly multi-talented. In addition to suitable shovels and mechanical or hydraulic pallet forks, it can also operate many other attachments.

With the auxiliary hydraulics and the electrical connection, a wide range of useful tools can be operated safely and with sufficient power.

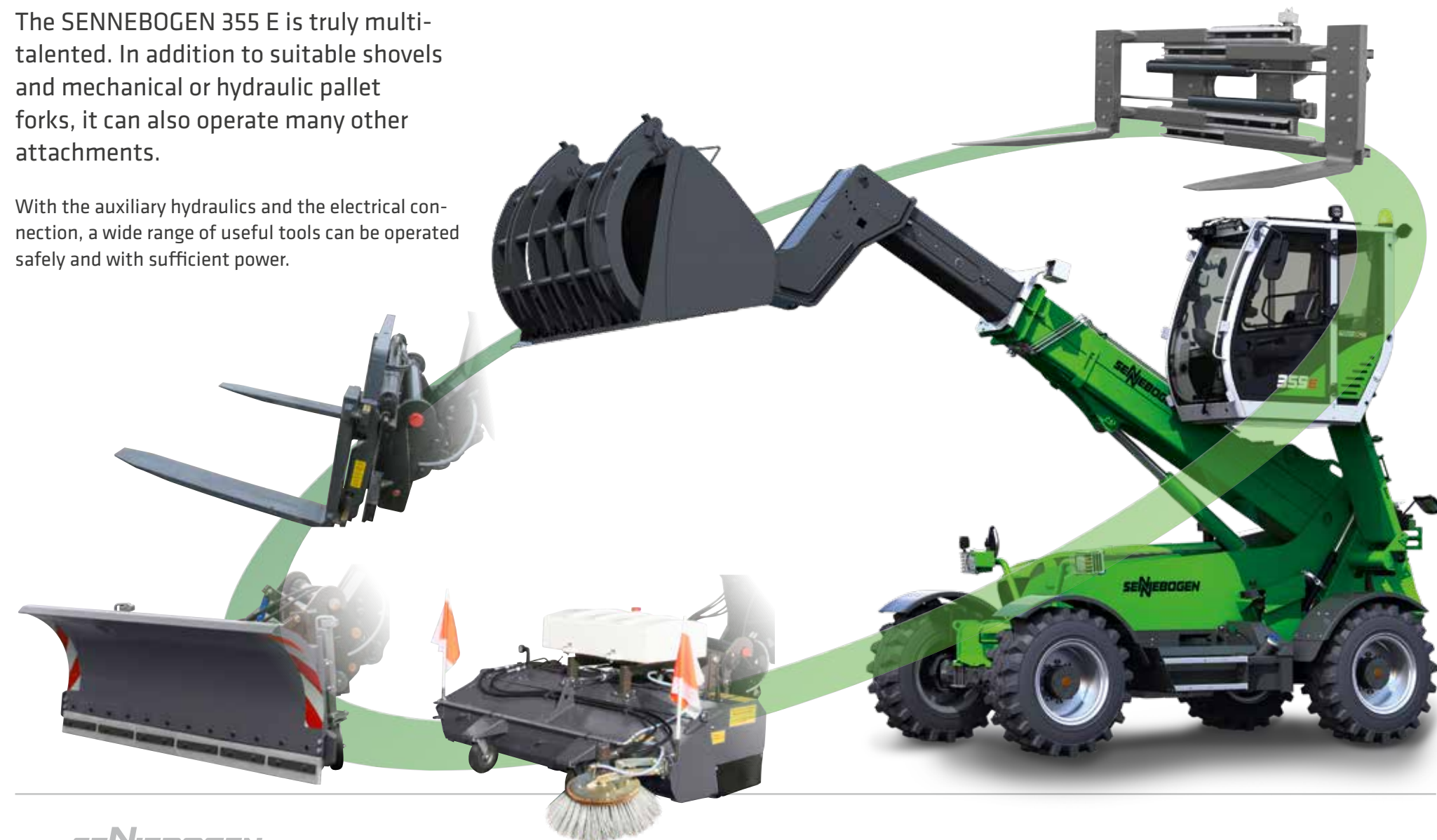

Image shows a selection of possible attachments. Availability on request. Subject to technical changes. Additional options available upon request.

## SERVICE: KEEP IT SIMPLE. WITH MANAGEABLE TECHNOLOGY.



Clear control panel and display console incl. error code display.



Spacious access to the engine compartment with just one handle. The side plate of the engine nacelle can also be removed.



Our service center offers you comprehensive technical support in the maintenance and repair of your machine - by telephone and on site.

Subject to technical changes. Additional options available upon request.

## OUR SERVICE PHILOSOPHY.



Reliable and practical technology makes life easier. Where electronics add no value, we rely on hydraulics and electrical systems.



We make you happy, not reliant. With cost-effective components and fewer process steps, you can take care of your own machine.



On the central electrical distribution board, the clearly arranged standard components facilitate control and troubleshooting.

### EXTENDED WARRANTY

SENNEBOGEN guarantees the steel components of the 355 E (in particular the frame and telescopic boom) for **three years or 10,000 operating hours**, whichever comes first. Talk to your sales partner about this offer!



IT'S ALL ABOUT MAINTENANCE. SIMPLE AND UNDERSTANDABLE.



MAINTENANCE AND SERVICE MADE EASY



Clearly arranged and easily accessible components.

<https://www.sennebogen.com/news/videos/sennebogen-sml-power-maintenance-and-service-made-easy>



1 All service points easy to access thanks to transversely mounted engine.



2 Very good access to the cooler thanks to the folding air conditioning condenser.



3 Telescopic boom slide guides are accessible from the outside – easy to maintain and long service life.



4 Important valves and electrics are protected and accessible from the outside, even when the telescopic boom is lowered.



5 Optimum access to the main fuse box with integrated overview plan.



6 Best possible access to the main manifold, hydraulic oil tank and return filter.





Ideal view even to the right over the telescopic boom



Efficient loading thanks to raised seating position





**SENNEBOGEN ACADEMY**

Increase your knowledge because success is based on knowledge. In the SENNEBOGEN Academy, we place great importance on ensuring knowledge flows powerfully. [www.sennebogen-academy.com](http://www.sennebogen-academy.com)



**SERVICE AND MAINTENANCE**

Comprehensive customer service. And supply of spare parts. Service is a TOP priority for us. [www.sennebogen.com/customer-service](http://www.sennebogen.com/customer-service)

**JOIN OUR OPERATORS' CLUB**



The spotlight is on you and your machine! We focus on exclusive information, sharing experiences with other SENNEBOGEN operators as well as fun and enthusiasm.

See all the benefits at [www.sennebogen.com/operators-club](http://www.sennebogen.com/operators-club)



over **72** years of experience

**100 %** family company

over **2200** experienced specialists worldwide

over **180** sales and service partners around the world

**5** production plants in Germany

over **60** different types of machine



**SENtrack**

Efficient fleet management with SENtrack: Use information that would otherwise stay hidden and increase your efficiency. [www.sennebogen.com/sentrack](http://www.sennebogen.com/sentrack)



**RENTAL & USED**

Discover the unique range of rental machines available from SENNEBOGEN Rental & Used. Rental machines can be found here: [www.sennebogen-rental-used.com](http://www.sennebogen-rental-used.com)



Telehandler  
4.0-5.5 t

Balancer  
130-300 t

Material handler  
17-420 t

Duty cycle crane  
13.5-300 t

Crawler crane  
50-300 t

Telecrane  
16-130 t

Port crane  
300 t



# 355E

Order no. 299214  
355-E-072110-032410

This catalog describes machine models, the scope of equipment of individual models, and configuration options (standard equipment and optional equipment) of the machines delivered by SENNEBOGEN Maschinenfabrik GmbH. Machine illustrations may contain optional and supplementary equipment. Actual equipment may vary depending on the country to which the machines are delivered, especially in regard to standard and optional equipment and tolerances. All product designations used may be trademarks of SENNEBOGEN Maschinenfabrik GmbH or other supplying companies, and any use by third parties for their own purposes may violate the rights of the owners.

Please contact your local SENNEBOGEN sales partner for information concerning the equipment variants offered. Requested performance characteristics are only binding if they are expressly stipulated upon conclusion of the contract. Delivery options and technical features are subject to change. All information is supplied without liability. Equipment is subject to change, and rights of advancement are reserved. © SENNEBOGEN Maschinenfabrik GmbH, Straubing, Germany. Reproduction in whole or in part only with written consent of SENNEBOGEN Maschinenfabrik GmbH, Straubing, Germany.

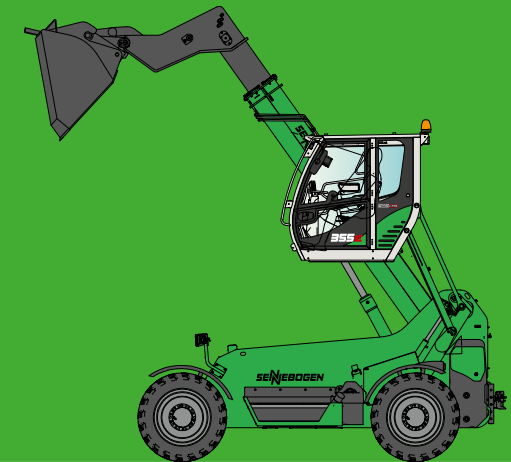

» [sennebogen.com/355](http://sennebogen.com/355)

**SENNEBOGEN**  
**Maschinenfabrik GmbH**  
Hebbelstraße 30  
94315 Straubing, Germany

➔ [www.sennebogen.com](http://www.sennebogen.com)

**MOVE BIG THINGS**

**SALES SENNEBOGEN**  
**Multi Line Sales**  
Tel. +49 9421 540-146  
[telehandler@sennebogen.com](mailto:telehandler@sennebogen.com)

**SPARE PARTS CENTER**  
**Spare parts orders**  
[spareparts@sennebogen.de](mailto:spareparts@sennebogen.de)

**AFTER SALES**  
**Technical support**  
[service@sennebogen.de](mailto:service@sennebogen.de)